

Mobile Crane Grue automotrice

LTM 1045-3.1

Technical Data Caractéristiques techniques

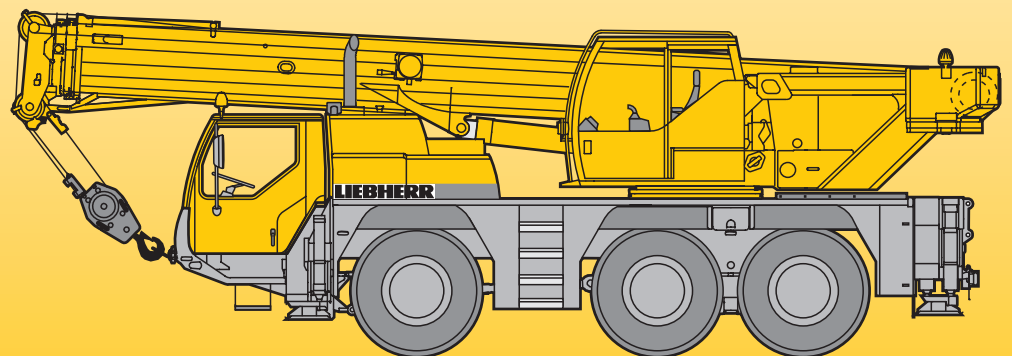

LIEBHERR

Lifting capacities on telescopic boom Forces de levage à la flèche télescopique

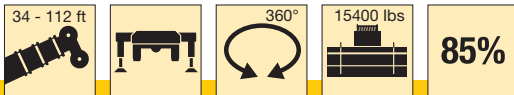

ft	34 ft		49 ft				65 ft	80 ft	96 ft	105 ft	112 ft		ft				
	*		*	**	**	**	**	**	**	**	**	**					
9	101	99.5											9				
10	101	98.5											10				
11	94.5	92.5					48.4						11				
12	89	87	58	51.5	58	51.5	55.6	48.4					12				
13	84	82	58.8	51.6	58.8	51.6	56.1	48.3					13				
14	79	77.5	59.6	51.8	59.6	51.8	56.2	48.2	33.4	20.8			14				
15	74.5	72.5	60.5	52	60.5	52	55.7	47.9	45.7	33.3	35.9	20.7	15				
16	72	68.5	61.5	52.2	61.5	52.2	53.6	47.1	45.2	33.1	36.4	20.5	29.6	12.7	16		
17	68.5	65	61	52.5	61	52.5	51.7	46.8	44.1	33	36	20.4	29.4	12.7	17		
18	65.5	61.5	59.4	52.8	59.3	52.8	49.9	46.7	42.7	32.8	35.1	20.2	29.2	12.5	24.2	6.7	18
20	58.7	55.1	56	52.9	55.7	52.7	46.4	46.2	40	32.5	33.4	19.7	28.7	12.2	24.1	6.7	20
22	50.2	49	51.4	50.4	50	49	43.3	43.3	37.7	32.3	31.9	18.4	28.2	11.9	23.4	6.5	22
24			46.6	46.6	44.7	44.7	40.3	40.3	35.5	32	30.4	17.7	27.4	11.6	22.7	6.3	24
26			41.4	41.4	39.8	39.8	37.3	37.3	33.4	31.8	28.9	17.4	26.3	11.3	22.1	6.1	26
28			37.5	37.5	36	36	33.9	33.9	31.3	30.6	27.6	17.1	25.3	11.1	21.4	5.9	28
30			34	34	32.5	32.5	30.6	30.6	29	29	26.3	16.9	24.3	10.8	20.8	5.7	30
32			31.1	31.1	29.4	29.4	27.9	27.9	26.6	26.6	25	16.7	23.3	10.6	20.1	5.5	32
34			28.6	28.6	26.9	26.9	25.7	25.7	24.5	24.5	23.5	16.5	22.2	10.1	19.6	5.4	34
36			26.3	26.3	24.7	24.7	23.8	23.8	22.7	22.7	21.8	16.3	20.9	9.4	19	5.2	36
38			24	24	22.5	22.5	21.9	21.9	21	21	20.1	16.1	19.6	8.8	18.5	5.1	38
40							20.2	20.2	19.4	19.4	18.6	15.9	18.3	8.3	17.8	4.9	40
45							16.6	16.6	16.3	16.3	15.8	15.3	15.5	8	15.3	4.6	45
50							14	14	13.8	13.8	13.5	13.5	13.3	7.7	13.2	4.3	50
55									11.8	11.8	11.7	11.7	11.5	7.4	11.4	4	55
60									10.1	10.1	10.1	10.1	10	7.2	9.9	3.8	60
65									8.5	8.5	8.6	8.6	8.5	7	8.5	3.6	65
70											7.4	7.4	7.4	6.8	7.4	3.1	70
75											6.5	6.5	6.5	6.4	6.5	2.5	75
80											5.8	5.8	5.7	5.6	5.7		80
85											5.1	5.1	5	4.5	5		85
90													4.5	3.5	4.4		90
95														4			95

* over rear / sur arrière

** telescopic loads / capacités de levage en télescopage

TAB 105045 / 105046





Remarks referring to load charts

- The tabulated lifting capacities do not exceed 85 % of the tipping load.
- The crane's structural steelwork is in accordance with DIN 15018, part 3. Design and construction of the crane comply with DIN 15018, part 2, and with F. E. M. regulations.
- The 85 % overturning limit values take into account wind force 5 = wind speed 20 mph.
- Lifting capacities are given in kips.
- The weight of the hook blocks and hooks must be deducted from the lifting capacities.
- Working radii are measured from the slewing centreline.
- The lifting capacities given for the telescopic boom only apply if the folding jib is taken off.
- Lifting capacities are subject to modifications.
- Lifting capacities above 93 kips only with additional pulley block.

Remarques relatives aux tableaux des charges

- Les forces de levage indiquées ne dépassent pas 85 % de la charge de basculement.
- La norme DIN 15018, 3ème partie est appliquée pour les charpentes. La construction de la grue est réalisée conformément à la norme DIN 15018, 2ème partie, et aux règles de la F. E. M.
- À 85 % de la charge de basculement, il a été tenu compte d'un vent de force 5 = vitesse de vent 20 mph.
- Les forces de levage sont données en kips.
- Les poids des mouffes et crochets doit être soustrait des charges indiquées.
- Les portées sont calculées à partir de l'axe de rotation.
- Les forces indiquées pour la flèche télescopique s'entendent fléchette dépliée.
- Les forces de levage sont modifiables sans préavis.
- Forces de levage plus de 93 kips seulement avec moufle additionnel.

Lifting capacities on telescopic boom Forces de levage à la flèche télescopique

34 - 112 ft   0°/360°  12300 lbs  **85%**

ft	34 ft		49 ft				65 ft		80 ft		96 ft		105 ft		112 ft		ft
	*	*	*	**	**	**	**	**	**	**	**	**	**	**	**		
9	99	90														9	
10	98	89.5														10	
11	93.5	84														11	
12	88.5	79														12	
13	84	74	58.8	51.6	58.8	51.6	54.5	48.3								13	
14	79	69.5	59.6	51.8	59.6	51.8	52.6	48.2	43.3	33.4	34.4	20.8				14	
15	74.5	65	59.9	52	59.9	52	50.6	47.9	42.9	33.3	34.3	20.7				15	
16	72	61.5	58.6	52.2	58.6	52.2	48.7	47.1	41.4	33.1	33.5	20.5	26.9	12.7		16	
17	68.5	58.4	56.9	52.2	56.7	52	47	46	40.1	33	32.7	20.4	26.7	12.7		17	
18	65.5	55.4	54.9	51.9	54.5	51.6	45.3	44.7	38.8	32.8	31.9	20.2	26.5	12.5	22	6.7	18
20	58.6	49.4	50.9	50.9	49.9	49.9	42.1	42.1	36.4	32.5	30.4	19.7	26.1	12.2	21.9	6.7	20
22	49.5	43.7	46.8	46.8	44.3	44.3	39.4	39.4	34.2	32.3	29	18.4	25.7	11.9	21.2	6.5	22
24			42.2	42.2	39.3	39.3	36.4	36.4	32.2	31.5	27.6	17.7	24.9	11.6	20.6	6.3	24
26			37.1	37.1	34.9	34.9	33.3	33.3	30.4	30.3	26.3	17.4	23.9	11.3	20.1	6.1	26
28			32.9	32.9	31.2	31.2	30.2	30.2	28.1	28.1	25.1	17.1	23	11.1	19.5	5.9	28
30			29.1	29.1	27.8	27.8	27.3	27.3	25.8	25.8	23.8	16.9	22.1	10.8	18.9	5.7	30
32			26.2	26.2	24.8	24.8	24.9	24.9	23.6	23.6	22.3	16.7	21.2	10.6	18.3	5.5	32
34			23.8	23.8	22.5	22.5	22.8	22.8	21.8	21.8	20.8	16.5	20.1	10.1	17.7	5.4	34
36			21.8	21.8	20.5	20.5	20.8	20.8	20.2	20.2	19.3	16.3	18.7	9.4	17.2	5.2	36
38			19.9	19.9	18.5	18.5	18.9	18.9	18.6	18.6	17.8	16.1	17.4	8.8	16.6	5.1	38
40							17.1	17.1	17.2	17.2	16.5	15.7	16.1	8.3	15.9	4.9	40
45							14	14	14.2	14.2	13.9	13.8	13.7	8	13.5	4.6	45
50							11.7	11.7	11.9	11.9	11.9	11.9	11.7	7.7	11.5	4.3	50
55									10	10	10.1	10.1	10	7.4	9.9	4	55
60									8.4	8.4	8.5	8.5	8.5	7.2	8.4	3.8	60
65									7.3	7.3	7.3	7.3	7.3	7	7.2	3.6	65
70											6.4	6.4	6.3	6.3	6.3	3.1	70
75											5.5	5.5	5.5	5.5	5.5	2.5	75
80											4.7	4.7	4.8	4.8	4.8		80
85											4.1	4.1	4.1	4.1	4.1		85
90													3.6	3.4	3.6		90
95															3.1		95

* over rear / sur arrière

** telescopic loads / capacités de levage en télescopage

TAB 105055 / 105057

34 - 49 ft   0°  15400 lbs  **85%**

ft	34 ft		49 ft		ft
				**	
9		39.2			9
10		38.5			10
11		33.8		32.5	11
12		29.8		30.8	12
13		26.5		27.4	13
14		23.9		24.8	14
15		21.5		22.4	15
16		19.6		20.5	16
17		18		18.9	17
18		16.6		17.5	18
20		14		14.8	20
22		12.1		12.9	22
24				11.2	24
26				9.8	26
28				8.7	28
30				7.7	30
32				6.8	32
34				6	34
36				5.4	36
38				4.7	38

0° = over rear / sur arrière

** telescopic loads / capacités de levage en télescopage

TAB 105037

Lifting capacities on the folding jib

Forces de levage à la fléchette pliante



ft	34 ft			96 ft						105 ft			112 ft			ft						
	0°	20°	40°	0° **	20° **	40° **	0° **	20° **	40° **	0° **	20° **	40° **	0° **	20° **	40° **							
9	15															9						
10	15															10						
11	15															11						
12	15															12						
13	15															13						
14	15	11.6														14						
15	15	11.6														15						
16	15	11.6														16						
17	15	11.6														17						
18	15	11.6		15	15				13.6	10.5						18						
20	14.9	11.6		14.9	14.9				13.6	10.4						20						
22	14.8	11.6	9.5	14.8	14.8				13.5	10.1			12.4	5.1		22						
24	14.6	11.6	9.5	14.6	14.6				13.4	9.3			12.4	5		24						
26	14.5	11.6	9.5	14.5	14.5				13.3	8.2			12.3	4.8		26						
28	14	11.4	9.5	14.3	14.3	11.6	11.6		13.1	7.8			12.2	4.6		28						
30	13.5	11.1	9.5	14.2	14.2	11.6	11.6		13	7.6			12.2	4.4		30						
32	12.8	10.7	9.5	13.9	13.9	11.4	11.4		12.9	7.4	10.8	7	12.1	4.2	10.3	4	32					
34	12.3	10.4	9.4	13.7	13.7	11.2	11.2		12.8	7.2	10.7	6.9	11.9	4	10.3	3.9	34					
36	11.7	10.1	9.4	13.5	13.5	11	11		12.5	7.1	10.6	6.7	11.6	3.9	10.2	3.7	36					
38	11.2	9.9	9.3	13.3	13.3	10.8	10.8	9.5	9.5	12.3	6.9	10.5	6.6	9.3	6.2	11.4	3.7	10.1	3.6	38		
40	10.7	9.6	9.2	13.1	13.1	10.6	10.6	9.4	9.4	12.1	6.7	10.4	6.4	9.2	6.2	11.1	3.6	10.1	3.5	40		
45	9.9	9.2	9	12.7	12.7	10.2	10.2	9.3	9.3	11.7	6.3	10.1	6	9.1	5.8	10.6	3.3	9.8	3.1	8.9	3	45
50	9.3	8.9		12.1	12.1	9.9	9.9	9.1	9.1	11.3	6	9.9	5.7	9	5.5	10.1	3	9.6	2.9	8.8	2.8	50
55				11.2	11.2	9.6	9.6	9	9	10.6	5.7	9.7	5.4	8.9	5.3	9.7	2.7	9.2	2.6	8.7	2.6	55
60				9.9	9.9	9.4	9.4	8.9	8.9	9.6	5.4	9.4	5.2	8.8	5	9.1	2.5	8.8	2.4	8.5	2.4	60
65				8.7	8.7	9.2	9.2	8.8	8.8	8.4	5.2	9	4.9	8.7	4.8	8.2	2.2	8.5	2.2	8.2	2.2	65
70				7.7	7.7	8.2	8.2	8.4	8.4	7.4	4.9	8	4.7	8.3	4.6	7.2	2	7.8	2	7.9	2	70
75				6.8	6.8	7.3	7.3	7.6	7.6	6.5	4.7	7.1	4.5	7.5	4.4	6.4		7	1.7	7.4	1.7	75
80				6	6	6.4	6.4	6.7	6.7	5.7	4.5	6.2	4.3	6.6	4.2	5.6		6.1		6.5		80
85				5.3	5.3	5.6	5.6	5.9	5.9	5.1	4.1	5.5	4.2	5.8	4.1	4.9		5.4		5.8		85
90				4.7	4.7	5	5	5.2	5.2	4.5	3.4	4.9	3.5	5.1	3.6	4.4		4.8		5.1		90
95				4.1	4.1	4.4	4.4			4	2.8	4.3	3	4.5	3	3.8		4.2		4.5		95
100				3.6	3.6	3.9	3.9			3.5	2.2	3.8	2.4			3.4		3.7		3.9		100
105				3.2	3.2	3.4	3.4			3		3.3	1.9			3		3.2				105
110				2.7	2.7	2.9	2.9			2.6		2.8	1.5			2.5		2.8				110
115										2.2		2.4				2.2		2.4				115
120																1.8		2				120

** telescopic loads / capacités de levage en télescopage

TAB 105047 / 105048 / 105049

Lifting capacities on the folding jib Forces de levage à la fléchette pliante



ft	34 ft			96 ft						105 ft				112 ft				ft				
	0°	20°	40°	0° **	20° **	40° **	0° **	20° **	40° **	0° **	20° **	40° **	0° **	20° **	40° **							
9	7.3															9						
10	7.3															10						
11	7.3															11						
12	7.3															12						
13	7.3															13						
14	7.3															14						
15	7.3															15						
16	7.3															16						
17	7.3															17						
18	7.2			7.2	7.2											18						
20	7.2			7.2	7.2											20						
22	7.1			7.1	7.1				6.5	6.5						22						
24	7.1			7.1	7.1				6.5	6.5						24						
26	7	5.6		7	7				6.5	6.5			6.4	4.3		26						
28	6.9	5.6		6.9	6.9				6.4	6.4			6.3	4.2		28						
30	6.8	5.6		6.8	6.8				6.4	6.4			6.3	4		30						
32	6.7	5.6		6.7	6.7				6.3	6.3			6.2	3.8		32						
34	6.6	5.6		6.6	6.6				6.3	6.3			6.2	3.7		34						
36	6.5	5.5		6.6	6.6				6.3	6.3			6.1	3.5		36						
38	6.4	5.5	4.4	6.5	6.5	5.5	5.5		6.2	6.2			6.1	3.4		38						
40	6.2	5.4	4.4	6.4	6.4	5.5	5.5		6.2	6.2			6	3.2		40						
45	5.8	5.1	4.4	6.2	6.2	5.3	5.3		6	5.8	5.2	5.2		5.9	2.9	5.1	2.7	45				
50	5.4	4.8	4.3	6.1	6.1	5.1	5.1		5.8	5.5	5.1	5.1		5.7	2.6	5	2.5	50				
55	5	4.5	4.2	5.9	5.9	5	5	4.3	4.3	5.7	5.2	4.9	4.9	4.2	4.2	5.6	2.3	4.8	2.3	4.2	2.1	55
60	4.7	4.3	4.1	5.6	5.6	4.8	4.8	4.2	4.2	5.5	4.9	4.8	4.6	4.2	4.2	5.5	2.1	4.7	2.1	4.2	2.1	60
65	4.4	4.2	4	5.5	5.5	4.7	4.7	4.2	4.2	5.4	4.6	4.6	4.4	4.1	4.1	5.3	1.9	4.6	1.9	4.1	1.9	65
70	4.2	4.1		5.3	5.3	4.6	4.6	4.1	4.1	5.2	4.4	4.5	4.2	4.1	4	5.2	1.7	4.5	1.7	4	1.7	70
75				5.1	5.1	4.5	4.5	4	4	5	4.1	4.4	3.9	4	3.8	5		4.4	1.5	4	1.5	75
80				5	5	4.3	4.3	4	4	4.9	3.9	4.3	3.8	3.9	3.6	4.9		4.3		3.9		80
85				4.8	4.8	4.2	4.2	3.9	3.9	4.8	3.7	4.2	3.6	3.9	3.5	4.7		4.2		3.9		85
90				4.7	4.7	4.2	4.2	3.9	3.9	4.5	3.6	4.2	3.4	3.9	3.3	4.4		4.1		3.9		90
95				4.3	4.3	4.1	4.1	3.9	3.9	4.1	3.3	4.1	3.2	3.9	3.2	4		4.1		3.9		95
100				3.9	3.9	4	4	3.9	3.9	3.7	2.8	4	3	3.9	2.9	3.5		3.9		3.8		100
105				3.5	3.5	3.9	3.9	3.9	3.9	3.2	2.2	3.8	2.5	3.9	2.5	3.1		3.7		3.8		105
110				3.1	3.1	3.5	3.5	3.7	3.7	2.9	1.8	3.4	2.1	3.6	2.2	2.7		3.2		3.6		110
115				2.7	2.7	3.1	3.1	3.3	3.3	2.5		3	1.7	3.3	1.8	2.4		2.9		3.2		115
120				2.3	2.3	2.7	2.7			2.2		2.6		2.8		2.1		2.5		2.8		120
125				2	2	2.3	2.3			1.9		2.2				1.8		2.1				125
130				1.7	1.7	1.9	1.9			1.6		1.9				1.5		1.8				130
135												1.5						1.5				135

** telescopic loads / capacités de levage en télescopage

TAB 105047 / 105048 / 105049

Lifting heights Hauteurs de levage

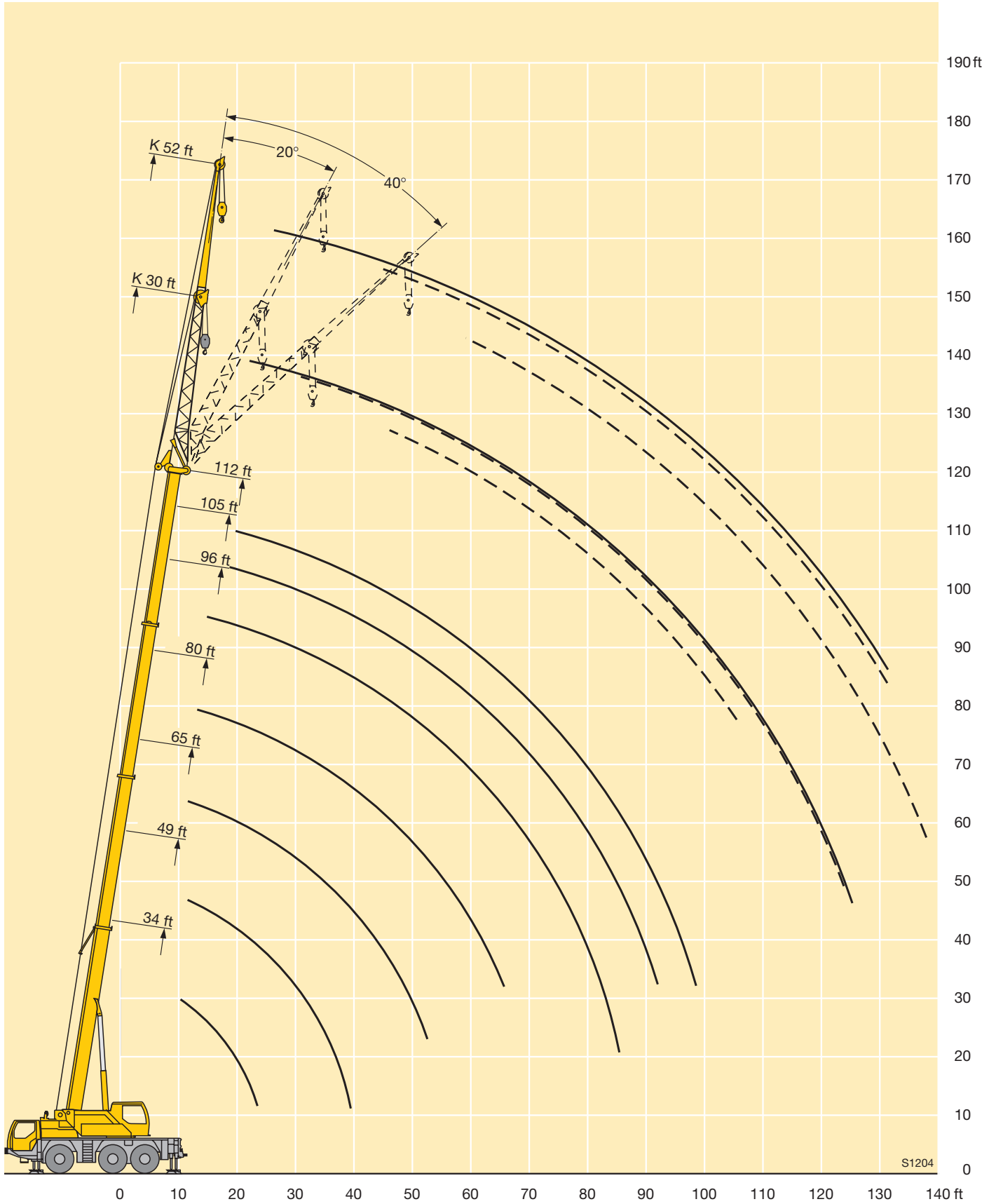

Dimensions Encombrement

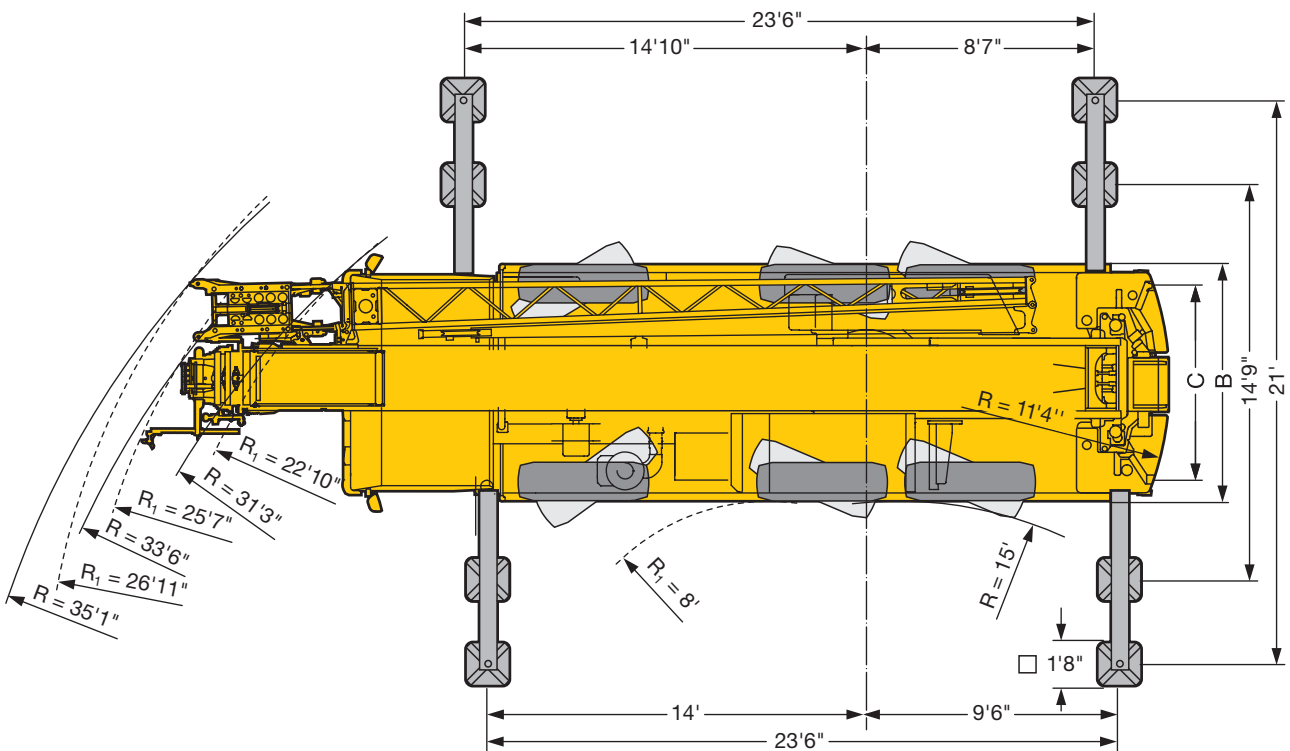
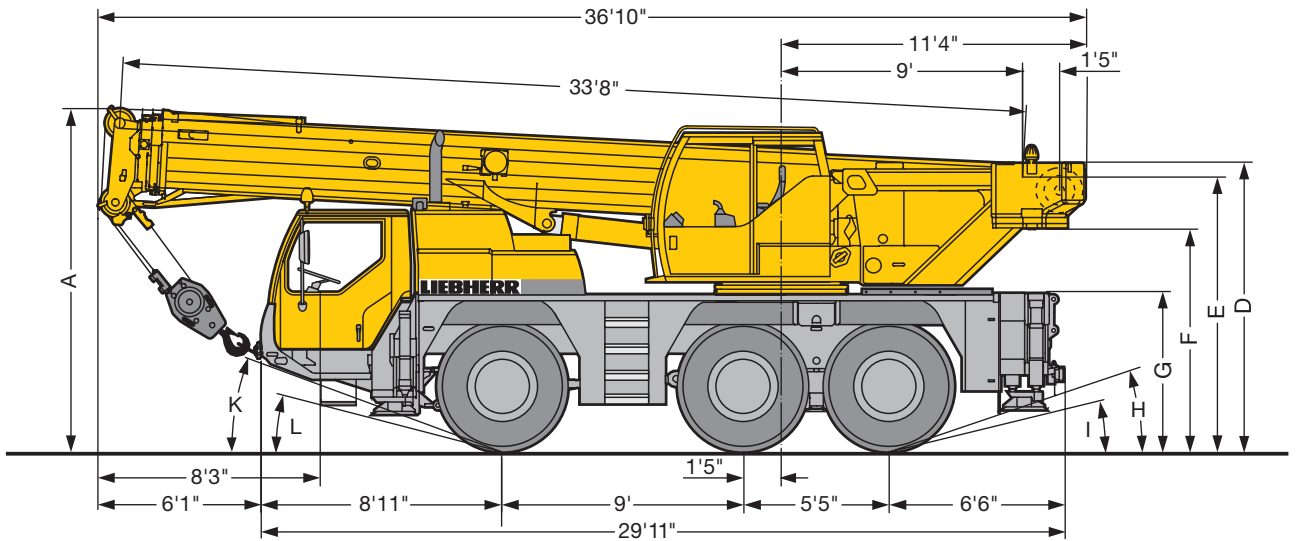

US2083

R₁ = All-wheel steering / Direction toutes roues

	Dimensions / Encombrement											
	A	A*	B	C	D	E	F	G	H	I	K	L
16.00 R 25	12'10"	12'6"	8'10"	7'4"	10'9"	10'1"	8'2"	5'9"	19°	15°	22°	17°
20.5 R 25	12'10"	12'6"	9'3"	7'5"	10'9"	10'1"	8'2"	5'9"	19°	15°	22°	17°

* lowered / abaissé

Weights Poids



Axle Essieu lbs	1	2	3	Total weight (lbs) Poids total (lbs)
	26400	26400	26400	79200 ¹⁾

¹⁾ with 15400 lbs counterweight and folding jib / avec contrepoids 15400 lbs et flèche pliante



Load (kips) Forces de levage (kips)	No. of sheaves Poulies	No. of lines Brins	Weight lbs Poids lbs
99	5	10	715
66.5	3	7	617
29.3	1	3	430
9.9	–	1	165

Working speeds Vitesses



16.00 R 25 20.5 R 25	mph	1	2	3	4	5	6	7	8	9	10	11	12	R 1	R 2	51.6 %
		1.2	1.6	2.1	2.6										1.3	



Drive Mécanismes	infinitely variable en continu	Rope diameter / Rope length Diam. du câble / Longueur du câble	Max. single line pull Effort au brin maxi.
	0 - 394 ft/min single line ft/min au brin simple	1/2" / 590'7"	10100 lbs
	0 - 2,4 rpm		
	approx. 46 seconds to reach 81° boom angle env. 46 s jusqu'à 81°		
	approx. 80 seconds for boom extension from 34 ft – 112 ft env. 80 s pour passer de 34 ft – 112 ft		

Equipment Equipment

Crane carrier

Frame	Liebherr designed and manufactured, box-type, torsion resistant design of high-tensile fine grained structural steel.
Outriggers	4-point support, all-hydraulic horizontal and vertical operation.
Engine	6-cylinder Diesel engine, make Liebherr, type D 926 TI-E A5, watercooled, 270 kW (367 HP) at 2100 rpm acc. to ECE-R 24.03 and 2001/27/EG (Euro 3), max. torque 1218 lbs-ft at 1400 rpm, electronic engine management. Fuel tank: 92 gallons.
Transmission	ZF 12-speed gear box with automatic control system AS-TRONIC. Two-stage transfer case with lockable transfer differential.
Axles	All axles steered. Axles 2 and 3 with planetary gears and differential locks.
Suspension	All axles with hydropneumatic suspension and hydraulic locking facility.
Tyres	6 tyres. Tyre size: 16.00 R 25.
Steering	Front axle mechanically steered, with hydraulic power assistance and stand-by steering pump. Rear axles hydraulically steered. All axles steered hydrostatically from crane cab. Steering acc. to EC directive 70/311/EEC.
Brakes	Service brake: All-wheel servo-air brake, dual circuit system. Hand brake: Spring-loaded, acting on all wheels of axles 1 and 2. Sustained-action brake: Exhaust retarder with additional Liebherr braking system. Anti-lock device in conjunction with anti-skid control. Brakes acc. to EC directive 71/320/EEC.
Driving cab:	Two-men driving cab, steel sheet design, cataphoretic dip-primed, mounted on rubber shock absorbers and on hydraulic dampers, safety glass windows, operating and control elements.
Electrical system	Control of the electrical and electronical components by modern data bus technique. 24 Volt DC, 2 batteries 170 Ah each, lighting according to traffic regulations.

Crane superstructure

Frame	Liebherr-made, torsion-resistant, welded construction of high-tensile structural steel, linked to carrier by a single-row ball bearing slewing ring, for continuous rotation.
Crane drive	Diesel-hydraulic with 1 axial variable displacement pump with automatic capacity control, 1 gear pump, driven by the carrier Diesel engine, open oil circuits with hydraulic "load sensing", operation of 4 movements simultaneously.

Crane control	Hydraulic pilot control of drives by self-centering joysticks, armrest-integrated control elements.
Hoist gear	Axial piston fixed displacement motor, hoist drum with integrated planetary gear and spring-loaded static brake, actuation by open regulated oil circuit.
Luffing gear	1 differential ram with pilot operated brake valve.
Slewing gear	Axial piston fixed displacement motor, planetary gear, spring-loaded static brake. Hydraulic pilot control, open oil circuit, with pedal for the combined control of the service and static brake. Continuous control of slewing speed.
Crane cab	Galvanized steel construction, powder coating, safety glazing, control elements and instruments for crane operation and travelling.
Safety devices	LICCON safe load indicator, hoist limit switch, safety valves against pipe and hose rupture, test system for servicing.
Telescopic boom	Buckling resistant and torsion-proof design of high tensile steel with oviform boom profile, 1 base section and 3 telescopic sections. The telescopes are extended by a three-stage hydromechanic telescoping system with double pulley block. Boom telescopic under partial load. Boom length: 34 ft – 112 ft.
Counterweight	15400 lbs
Electric system	Control of the electrical and electronical components by modern CAN bus and Liebherr system bus (LSB).

Complementary equipment

Folding jib	Single folding jib, 30 ft long, installation at 0°, 20°, 40° or 60°. Double folding jib, 30 ft – 52 ft long, installation at 0°, 20°, 40° or 60°.
Erection jib	Consisting of the adapter of the swing-away jib and an additional pulley set, 1.4 m long, mountable at 0°, 20°, 40° or 60°.
Tyres	6 tyres. Tyre size: 20.5 R 25.
Drive 6 x 6	Axle 1 additionally driven.

Other item of equipments available on request.

Equipment Équipement

Châssis porteur

Châssis	Fabrication Liebherr, construction en caisson indéformable, en acier à haute résistance à grains fins.
Stabilisateurs	Calage en 4 points, à telescopage horizontal et vérinage entièrement hydrauliques.
Moteur	Diesel, 6 cylindres, marque Liebherr, type D 926 TI-E A5, refroidi par eau, puissance 270 kW (367 ch) à 2100 rpm selon ECE-R 24.03 et 2001/27/EG (Euro 3), couple max. 1218 lbs-ft à 1400 rpm, gestion électronique. Réservoir à carburant: 92 gallons.
Boîte de vitesse	Boîte de vitesses ZF à 12 rapports, mécanisme automatisé à commande AS-TRONIC. Boîte de transfert à 2 étages avec blocage de différentiel.
Essieux	Tous les essieux sont directeurs. Les essieux 2 et 3 avec planétaires et blockages de différentiels.
Suspension	Tous les essieux sont suspendus hydropneumatiquement et blocable hydrauliquement.
Pneumatiques	6 roues. Taille: 16.00 R 25.
Direction	Direction mécanique à assistance hydraulique de l'essieu avant. Pompe de secours. Direction des essieux arrières enclenchable hydrauliquement. Direction hydrostatique de tous les essieux à commande depuis la cabine du grutier. Direction selon directive CE 70/311/CEE.
Freins	Frein de service: à double circuit assisté pneumatiquement, sur toutes les roues. Frein à main: par cylindres à ressorts, agissant sur les roues des essieux 1 et 2. Frein à régime continu: Ralentisseur sur échappement avec système de freinage additionnel Liebherr. Dispositif anti-enrayeur avec contrôle anti-patinage. Freins selon directive CE 71/320/CEE.
Cabine	Cabine conducteur bi-place en tôle d'acier revêtue anti-corrosion par bain de cataphorèse, suspendue sur silent blocs et amortissement hydraulique vitrage de sécurité, tableau de bord complet.
Installation électrique	Composants électriques et électroniques reliés entre eux par bus de données moderne. Courant continu 24 Volts, 2 batteries à 170 Ah chacune, éclairage conforme au code de la route.

Partie tournante

Châssis	Fabrication Liebherr, construction mécanosoudée en tôle d'acier à haute résistance à grains fins. La couronne d'orientation à 1 rangée de billes, permettant une rotation illimitée, sert d'élément de liaison vers le châssis de la grue.
----------------	--

Entraînement	Diesel hydraulique avec 1 pompe double à débit variable et régulation de puissance automatique, 1 pompe à engrenages, entraînée par le moteur Diesel du porteur, circuits hydrauliques ouverts avec "load sensing" hydraulique. 4 mouvements simultanés praticables.
Commande	Servo-commande hydraulique de l'entraînement via le manipulateur en croix avec retour automatique en position neutre, commandes de grue „grand confort“ intégrées aux accoudoirs du siège.
Treuil	Moteur hydraulique à cylindrée constante, treuil à réducteur planétaire incorporé et frein d'arrêt à ressort, en circuit hydraulique ouvert ou fermé et régulé.
Relevage de flèche	1 vérin différentiel à soupape pilotage de freinage.
Orientation	Moteur hydraulique à cylindrée constante, réducteur planétaire, frein d'arrêt à ressort. Servo-commande hydraulique, circuit hydraulique ouvert avec pédale conçue comme frein de service et frein de stationnement. Vitesse d'orientation réglable en continue.
Cabine de grue	En tôle d'acier galvanisée, peinte par poudrage polyester et cuisson au four, avec vitrage de sécurité, dotée de tous les éléments de contrôle et de commande pour l'opération et la conduite de la grue.
Sécurités	Contrôleur de charge LICCON, fin de course crochet haut, clapets de sécurité en cas de ruptures de flexibles. Système de test pour faciliter l'entretien.
Flèche télescopique	Construction en acier de haute résistance à grains fins à profil oval à haute résistance au flambage, 1 élément de base et 3 éléments télescopiques. Les éléments télescopiques sont sortis via une poulie moufle à 2 brins grâce à un système de telescopage hydromécanique à 3 positions. Flèche télescopable sous contrepoids partiel. Longueur de flèche: 34 ft – 112 ft.
Contrepoids	15400 lbs.
Circuit électrique	Commande des composants électriques et électroniques avec bus CAN et bus de système Liebherr (LSB).

Équipement optionnel

Fléchette pliante	Fléchette pliante simple, longueur 30 ft, montable à 0°, 20°, 40 ou 60°. Fléchette pliante double, longueur 30 ft – 52 ft, montable à 0°, 20°, 40 ou 60°.
Fléchette de montage	Se compose de l'adaptateur de la fléchette pliante et d'un jeu de poulies supplémentaire, présente une longueur de 1,4 m, peut être montée sous 0°, 20°, 40° ou 60°.
Pneumatiques	6 roues. Taille: 20.5 R 25.
Entraînement 6 x 6	Essieu 1 est entraîné additionnellement.

Autres équipements supplémentaires sur demande.